

Optronis

Make time visible

CamRecord

CR4000x2



HIGH-SPEED VIDEO CAMERA

new

- > **500 fps with full resolution**
 - 800 fps with full HD resolution**
- > **Very compact housing**
- > **Sensor Resolution 4 MPixel**
- > **Gigabit Ethernet Interface**
- > **Monochrome and color sensor**
- > **Up to 8 GB internal memory**
- > **User friendly software**

CamRecord CR4000x2

To capture movement does not mean to lose dynamics.

Performance (Examples)

Framerate / second (maximum)	Resolution (H x V)	Recording Time (8 GB, 8 Bit, max. Framerate)
500 fps	2304 x 1720	4 sec
560 fps	2048 x 1536	4,5 sec
750 fps	2048 x 1152	4,5 sec
800 fps	1920 x 1080	4,5 sec
100 000 fps Max. Speed	2304 x 4	16 sec
UltraSpeed	see Model Overview	

Model Overview

CR4000x2 /options	Description
/2GB /4GB or /8GB	Memory size in GigaByte
/M or /C	Monochrome or color sensor
/FM or /CM	Nikon F-Mount or C-Mount
/US	UltraSpeed (Framerate up to x2 depending on Exposure Time, only for Monochrome Sensor)

Optional Accessories

LabView driver (Part number CR-LabView)

Software development kit (Part number CR-SDK)

Lenses, lights, tripod, trigger switches and more accessories on request.

Connector Pin Assignment

4-pin LEMO FGG0B304CLAD52Z

Pin 1	Sync IN	Pin 3	GND
Pin 2	Trig IN	Pin 4	Sync OUT

Specifications

Sensor Resolution	2304 x 1720 pixel
Frame Rate @ Max. Sensor Res.	500 fps
Image Sensor	Progressive Scan CMOS
Exposure Time	2 μ s - 1/Framerate
Active Area	16,13 mm x 12,04 mm
Sensor Diagonal Dimension	20,12 mm
Pixel Size	7 μ m
A/D Conversion	8 Bit, 10 Bit
Dynamic	10 Bit
Sensitivity	9000 bits / lux*second (monochrome)
Shutter Efficiency	global electronic shutter, min. 2 μ s exposure time / > 99.9 %
Trigger Signal	TTL, switch, open collector, rising or falling edge, on image content variation
Synchronization	internal, external
Interface	Gigabit Ethernet
Video Output	VGA
Power	12 VDC / 12 W
Lens Mount	Nikon F-Mount (optional C-Mount)
Weight	1050 g
Operating Temperature	0 .. 40°C
Humidity	< 80 % relative, non-codensed
Dimensions	145 mm x 95 mm x 78,5 mm
Conformity	CE, RoHS
Scope of delivery	Camera CR4000x2, 5 m GigE cable, power supply, manual, trigger cable and TimeBench software for Windows XP, Vista and Windows 7.

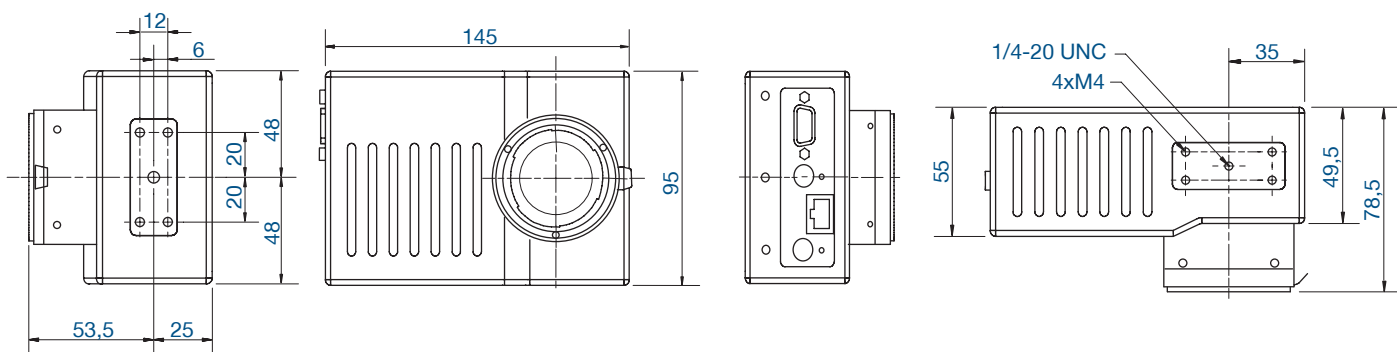

The information given herein is believed to be reliable, however Optronis makes no warranties as to its accuracy or completeness. Data sheet is subject to modifications at any time. 07/2010

Optronis

Make time visible

Optronis GmbH

Honsellstr. 8
77694 Kehl, Germany

Telefon +49 (0) 7851 / 9126-0
Telefax +49 (0) 7851 / 9126-10

E-Mail: info@optronis.com
www.optronis.com